

NER/ER Cylinder Control Electric Chain Hoists with Hook and Lug Suspensions



NER003SCC

We have expanded the benefits of the ergonomically designed cylinder control into our full-featured NER/ER Series of electric chain hoists. For three-phase applications requiring ease of control, one-handed operation, fast lifting speeds and heavy duty production, these hoists will increase productivity, add to operator comfort and answer your ergonomic needs.

Features and Benefits

Easy Access Suspension

External pins allow for quick change from hook to lug for trolley mount configurations on most models.

Green Initiative

Built smarter without the use of harmful materials. Environmentally friendly. RoHS compliant.

Notched Hook and Latch System

Provides positive closing and improves resistance against lateral forces.

Limit Switches

Low-profile upper and lower limit switches are standard.

Extended Chain Life

Decreased chain wear as a result of a revolutionary heat treatment process, improved material and chain size.

Low/High Speeds

Rocker switch above handgrip on dual speed models allows quick selection of low or high speed.

High Air Flow

Cooler motor and brake attributed to an engineered motor fin, fan blade and fan cover design.

Unique Load Sheave

Increased number of pockets reduce chain vibration and increase chain life. 5 pockets standard; 6 pockets on smaller body hoists.

Friction Clutch and Load Brake

Friction clutch is standard on NER/ER models and friction clutch with mechanical load brake standard on ER models. Carbon friction material provides consistent performance over a wide temperature range.

Standard Count Hour Meter

Records and displays the number of lowering starts and hoist on time which is valuable for preventive maintenance. Integral to VFD on dual speed models.

Removable Bottom Hook

Permits insertion of below-the-hook devices.

Contactors

Mechanically interlocked, heavy-duty contactors on single speed models.

High Strength, Corrosion and Wear Resistant Load Chain

Grade 80, super strength, nickel-plated load chain, certified to DIN standards, uses unique technology to greatly increase resistance to fatigue and wear.

Dual Speed VFD

Under-the-cover VFD standard for dual speed hoists. Speed ratio is 6:1 with adjustability up to 12:1.

“The Guardian”: Smart Brake Technology

A current driven electromagnetic brake does not release unless the motor is energized. 10 year hoist brake warranty.

Unique Cylinder Control

In-line handgrip permits one handed operation. Available on hoist or as a kit for field installation.

Standard Hoist Specifications

Capacity Range

NER/ER – 1/8 Ton – 1/4 Ton

Standard Voltage

208-230 / 460-3-60
Optional voltages available
Dual speed models are not reconnectable

Control Voltage

110V (optional 24V)

Duty Cycle*

Single Speed – 60 Min.
Dual Speed – 30/10 Min. with VFD

Classification*

ASME H4
ISO M5
FEM 2m or 1Am

Ratings

Hoist – IP55
Pendant – IP65

Upper/Lower Limit Switch

Overwinding / overlifting device
Standard on all models

Chain Falls

Single chain fall

Standard Lift

6' (longer lifts not available)

Standard Reach

9' (approx)
(reach equals lift plus headroom)

Standard Power Supply Length

15' (longer lengths available)

Mounting

Hook, lug or trolley

Standard Pendants

Single speed: 2-button (momentary contacts)
Dual speed: 2-button (momentary contacts) with emergency On/Off (maintained contacts)

Chain Containers

Standard
Plastic

Operating Conditions

Recommended for -4° to +104° F and humidity of 85% or less.

NER vs. ER Features

ER model has same high-quality features as NER plus the following:

- Second brake—Weston-style mechanical load brake

*See page 59 for additional information.

HARRINGTON ELECTRIC CHAIN HOISTS



NER003SCC

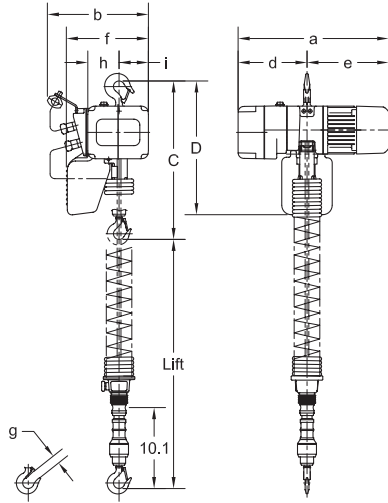

NER003SCC

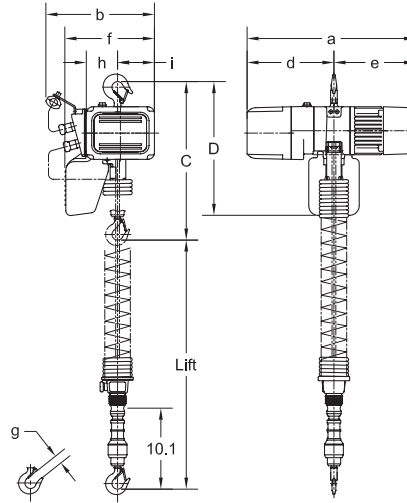

NER003SDCC

Dimensions for NER/ER
Cylinder Control Model (inches)

NER/ER CYLINDER CONTROL — SINGLE SPEED SPECIFICATIONS

Cap. (Tons)	Product Code	Standard Lift (ft)	Lifting Speed (ft/min)	Lifting Motor 3 Phase 60 Hz			Load Chain Diameter (mm) x Chain Fall Lines	Net Weight (lbs)	
				Output (Hp)	Rated Current (amps)			NER	ER
					@208 – 230V	@460V			
1/8	(N)ER001HCC	6	55	0.75	3.4	1.7	4.3 x 1	66	68
1/4	(N)ER003SCC	6	36	0.75	3.4	1.7	4.3 x 1	66	68

SINGLE SPEED DIMENSIONS

Cap. (Tons)	Product Code	Headroom C (in)	D (in)	a (in)		b (in)		d (in)		e (in)	f (in)		g (in)	h (in)	i (in)	
				NER	ER	NER	ER	NER	ER		NER	ER			NER	ER
1/8	(N)ER001HCC	41.9	19.3	18.8	22.2	12.6	13.6	8.6	12.0	10.2	10.2	11.2	1.1	3.9	3.7	4.6
1/4	(N)ER003SCC	41.9	19.3	18.8	22.2	12.6	13.6	8.6	12.0	10.2	10.2	11.2	1.1	3.9	3.7	4.6

NER/ER CYLINDER CONTROL — DUAL SPEED SPECIFICATIONS

Cap. (Tons)	Product Code	Standard Lift (ft)	Lifting Speed (ft/min)	Lifting Motor 3 Phase 60 Hz*			Load Chain Diameter (mm) x Chain Fall Lines	Net Weight (lbs)	
				Output (Hp)	Rated Current (amps)			NER	ER
					@208 – 230V	@460V			
1/8	(N)ER001HDCC	6	55/9	0.75	3.6	1.8	4.3 x 1	64	68
1/4	(N)ER003SDCC	6	36/6	0.75	3.6	1.8	4.3 x 1	64	68

*Although both 208/230 & 460 Volts are shown together, the motors are **NOT** reconnectable.
Speed ratio is 6:1 with adjustability up to 12:1.

DUAL SPEED DIMENSIONS

Cap. (Tons)	Product Code	Headroom C (in)	D (in)	a (in)		b (in)	d (in)		e (in)	f (in)	g (in)	h (in)	i (in)
				NER	ER		NER	ER					
1/8	(N)ER001HDCC	41.9	19.3	21.1	22.2	13.6	10.9	12.0	10.2	11.2	1.1	3.9	4.6
1/4	(N)ER003SDCC	41.9	19.3	21.1	22.2	13.6	10.9	12.0	10.2	11.2	1.1	3.9	4.6